

**isc Silicon NPN Power Transistor**

**2SC2654**

**DESCRIPTION**

- High Collector Current::  $I_C = 7A$
- Low Collector Saturation Voltage  
:  $V_{CE(sat)} = 0.3(V)(Max) @ I_C = 3A$
- Complement to Type 2SA1129

**APPLICATIONS**

- Designed for low-frequency power amplifiers and mid-speed switching applications.
- Ideal for use in a lamp driver.

**ABSOLUTE MAXIMUM RATINGS( $T_a=25^\circ C$ )**

SYMBOL	PARAMETER	VALUE	UNIT
$V_{CBO}$	Collector-Base Voltage	100	V
$V_{CEO}$	Collector-Emitter Voltage	40	V
$V_{EBO}$	Emitter-Base Voltage	7	V
$I_C$	Collector Current-Continuous	7	A
$I_{CM}$	Collector Current-Peak	15	A
$I_B$	Base Current- Continuous	3.5	A
$P_C$	Total Power Dissipation @ $T_a=25^\circ C$	1.5	W
	Total Power Dissipation @ $T_c=25^\circ C$	40	
$T_J$	Junction Temperature	150	$^\circ C$
$T_{stg}$	Storage Temperature Range	-55~150	$^\circ C$

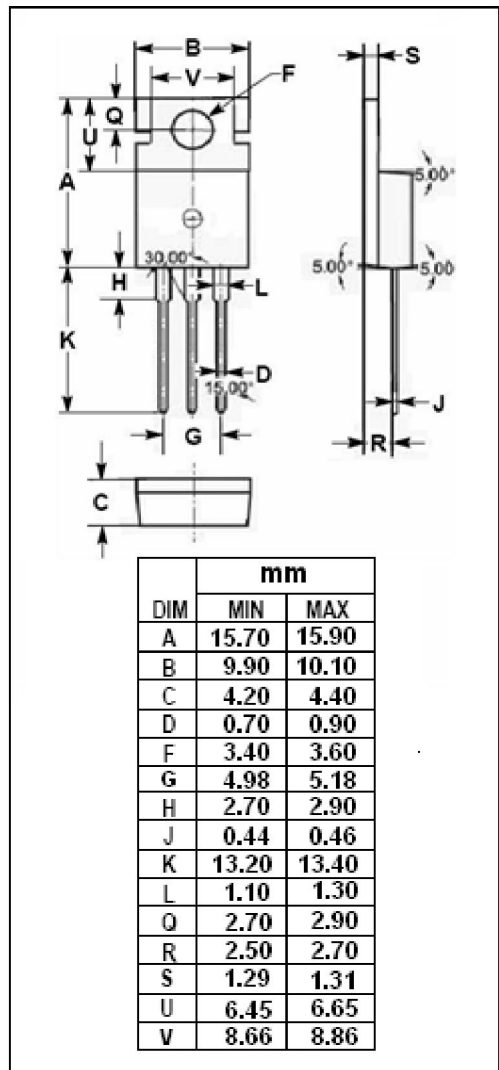
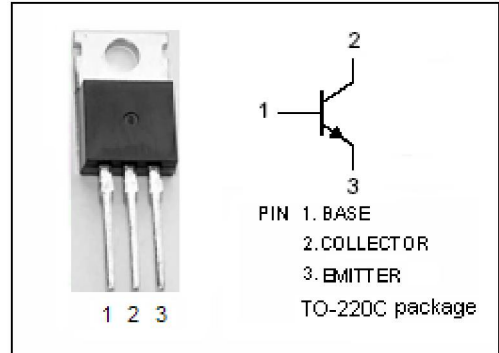

## isc Silicon NPN Power Transistor

## 2SC2654

## ELECTRICAL CHARACTERISTICS

 $T_c=25^{\circ}\text{C}$  unless otherwise specified

SYMBOL	PARAMETER	CONDITIONS	MIN	TYP.	MAX	UNIT
$V_{CE(sat)-1}$	Collector-Emitter Saturation Voltage	$I_C=3A; I_B=0.1A$			0.3	V
$V_{CE(sat)-2}$	Collector-Emitter Saturation Voltage	$I_C=5A; I_B=0.5A$			0.6	V
$V_{BE(sat)-1}$	Base-Emitter Saturation Voltage	$I_C=3A; I_B=0.1A$			1.5	V
$V_{BE(sat)-2}$	Base-Emitter Saturation Voltage	$I_C=5A; I_B=0.5A$			2.0	V
$I_{CBO}$	Collector Cutoff Current	$V_{CB}=40V; I_E=0$			10	$\mu A$
$I_{EBO}$	Emitter Cutoff Current	$V_{EB}=5V; I_C=0$			10	$\mu A$
$h_{FE-1}$	DC Current Gain	$I_C=3A; V_{CE}=1V$	40		320	
$h_{FE-2}$	DC Current Gain	$I_C=5A; V_{CE}=1V$	20			

## Switching Times

$t_{on}$	Turn-on Time	$I_C=5A, R_L=4\Omega, I_{B1}=-I_{B2}=0.5A, V_{CC}\approx 20V$			1.0	$\mu s$
$t_{stg}$	Storage Time				2.5	$\mu s$
$t_f$	Fall Time				1.0	$\mu s$

◆  $h_{FE-1}$  Classifications

M	L	K	J
40-80	60-120	100-200	160-320